

# Lockable DW Cutout Shelf panels

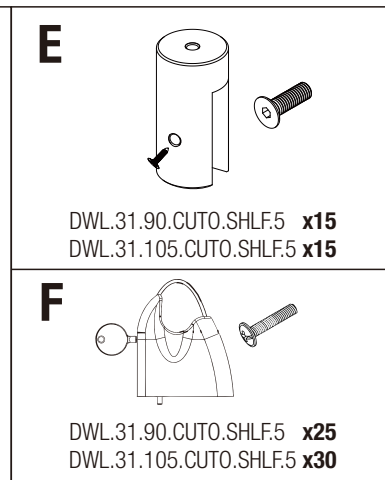

Place the back panel on the wall and mark standoff holes.

Step 1

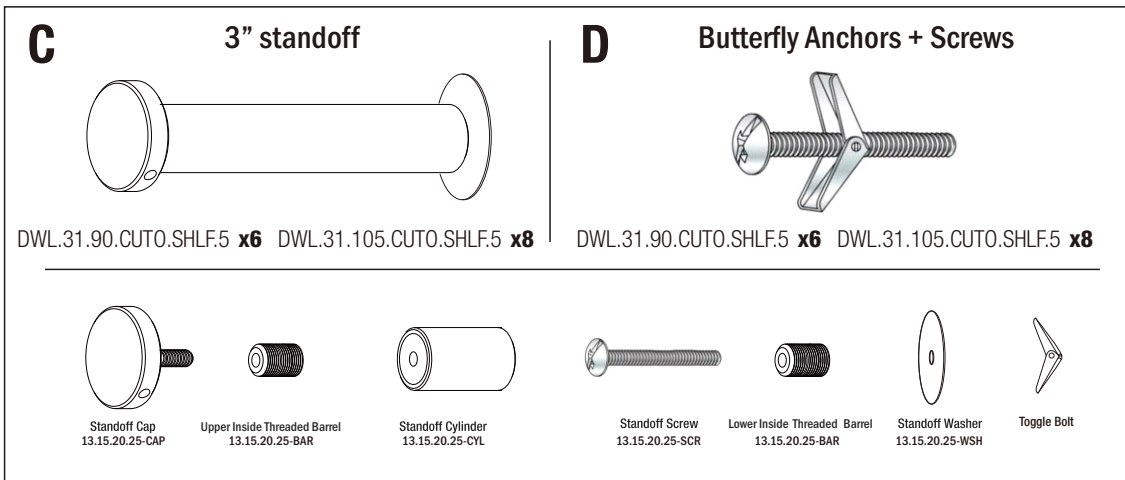
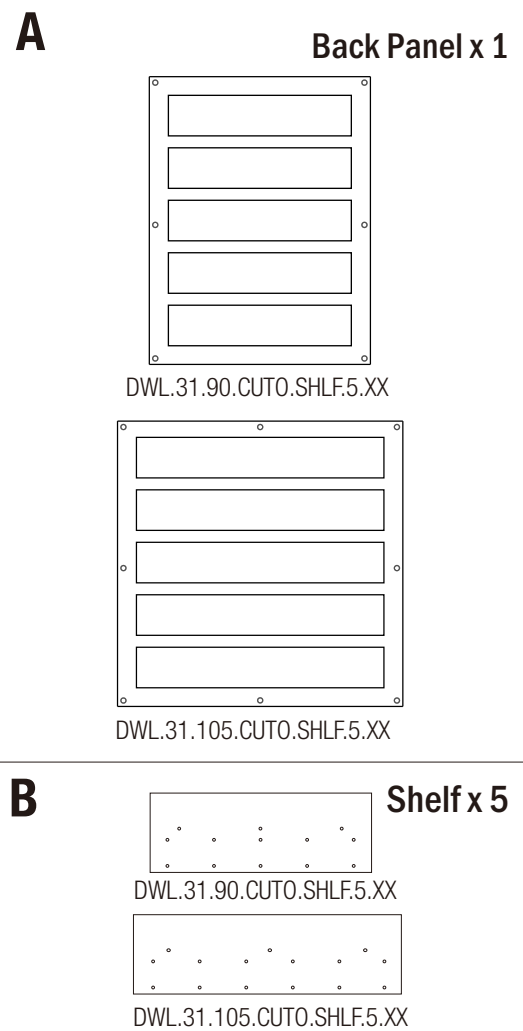
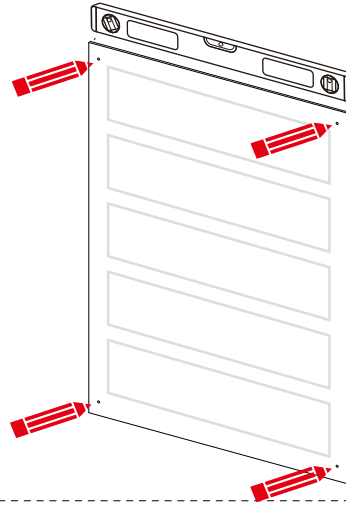

Install the standoffs on the marked spots on the wall

Step 2

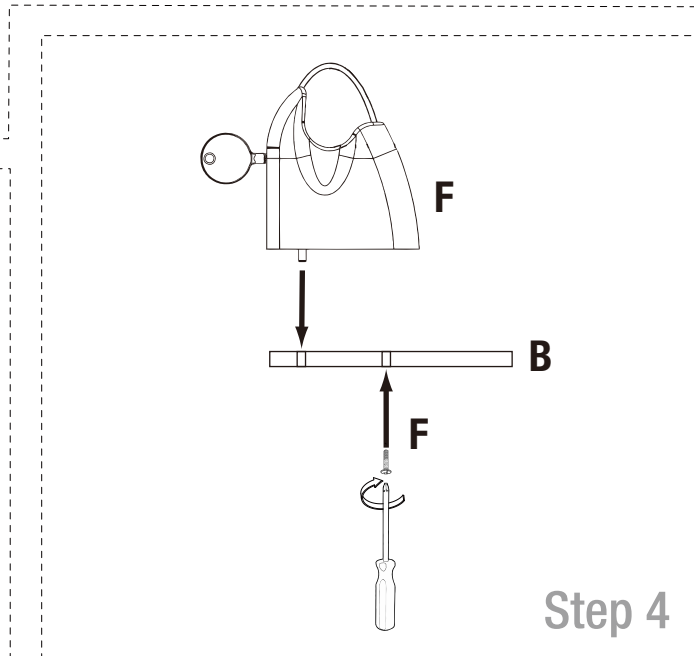
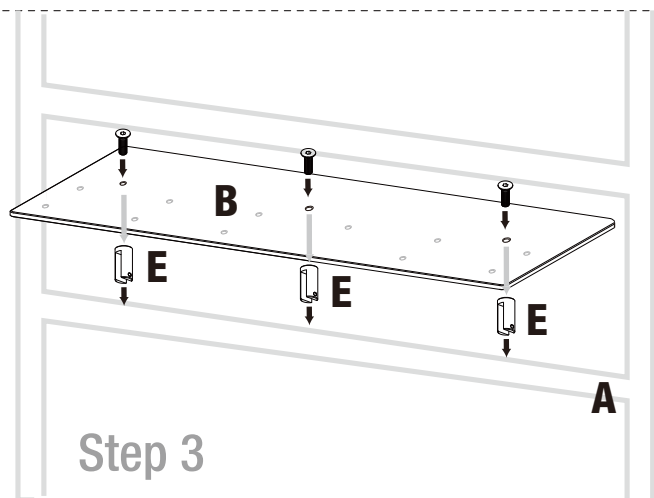
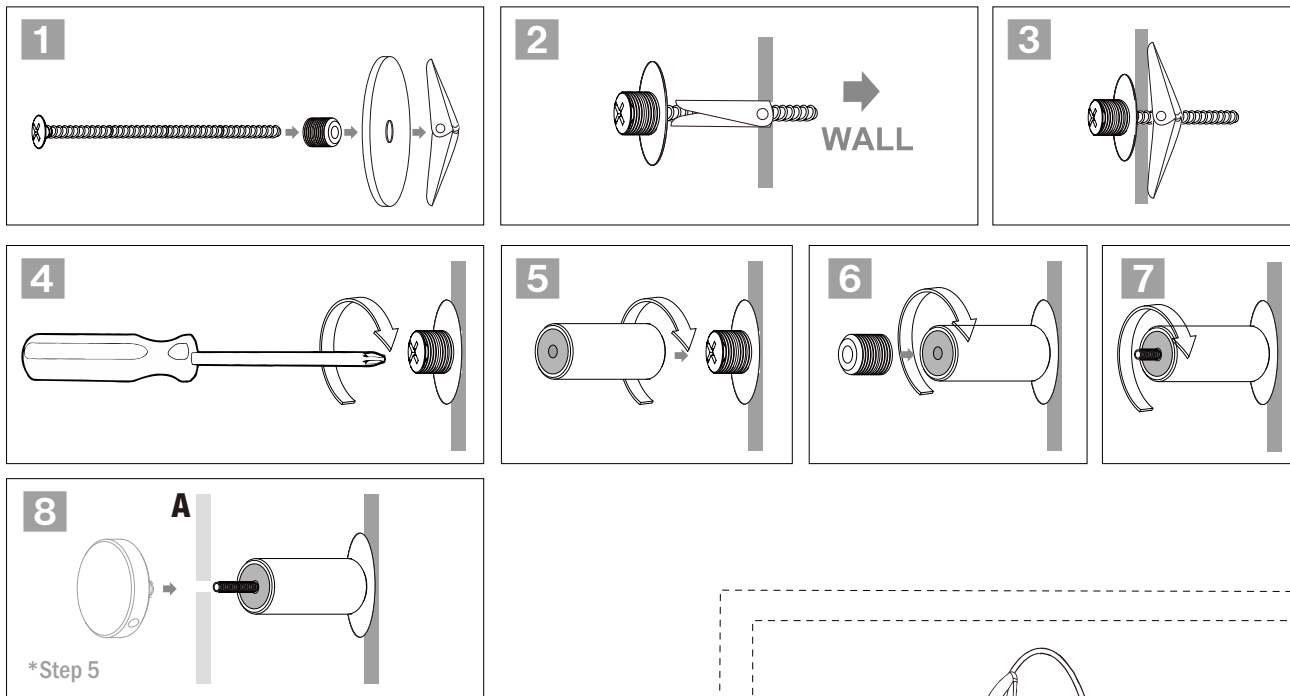

Place the complete panel and shelves on to the standoffs  
and secure them with the caps

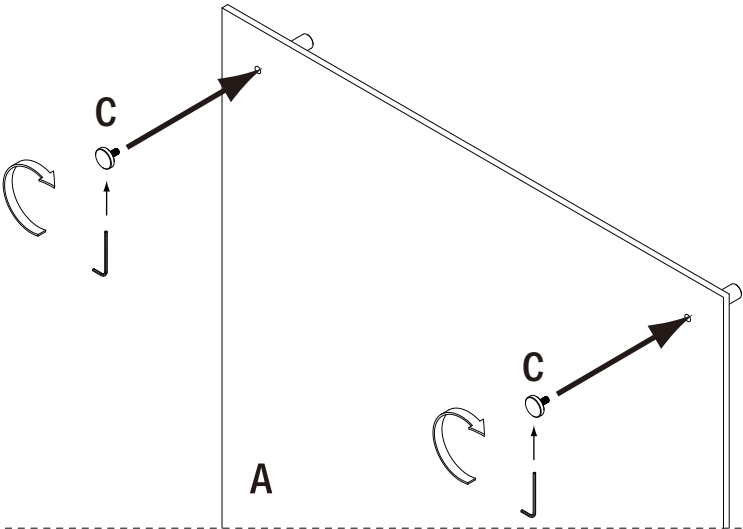

Step 5